

LINN

KLIMAX

Loudspeaker System

English

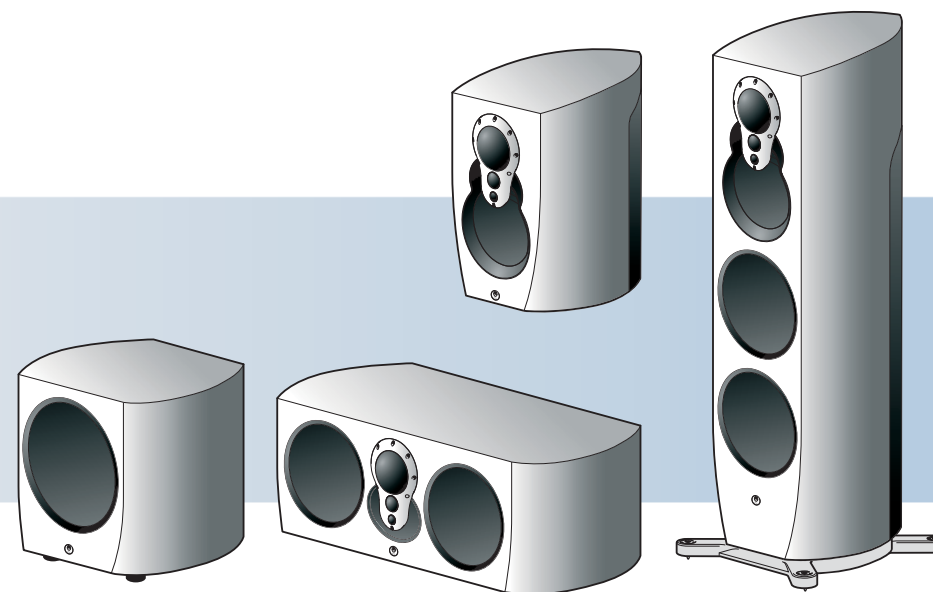

Owner's Manual

Copyright and Acknowledgements

Copyright © 2008 Linn Products Ltd. First edition April 2008.

Linn Products Limited, Glasgow Road, Waterfoot, Eaglesham, Glasgow, G76 0EQ, Scotland, United Kingdom

All rights reserved. No part of this publication may be reproduced, stored in a retrieval system, or transmitted, in any form or by any means, electronic, mechanical, photocopying, recording, or otherwise, without the prior written permission of the publisher.

Printed in the United Kingdom.

Trade marks used in this publication: **Linn** and the **Linn logo** are registered trade marks of Linn Products Limited. **Klimax**, **Kisto**, **Aktiv**, **Sekrit**, **Chakra** and **Skeets** are trade marks of Linn Products Limited.

The information in this manual is furnished for informational use only, is subject to change without notice, and should not be construed as a commitment by Linn Products Limited. Linn Products Limited assumes no responsibility or liability for any errors or inaccuracies that may appear in this manual.

Linn Products Limited disclaims any proprietary interest in trade marks and trade names other than its own.

Klimax 350 - UK Registered Design no: 3014677

Klimax 340 - UK Registered Design no: 3014676

Klimax 320 - UK Registered Design no: 3014671

Klimax 345 - UK Registered Design no: 3014675

Contents

| | | | |
|---|----------|--|-----------|
| Introduction | 1 | | |
| The Klimax system | 1 | | |
| Klimax features | 3 | | |
| Aktiv operation | 5 | | |
| Klimax 350, 340 and 320 | 7 | | |
| Unpacking | 7 | | |
| Fabric grilles | 7 | | |
| Cleaning | 7 | | |
| Positioning and levelling | 8 | | |
| Positioning | 8 | | |
| Levelling | 9 | | |
| Connecting | 10 | | |
| General | 10 | | |
| Connection of standard 350 model | 10 | | |
| Wiring and amping options | 11 | | |
| Link strip information | 11 | | |
| Single-wiring | 12 | | |
| Bi-wiring or bi-amping | 12 | | |
| Tri-wiring or tri-amping | 12 | | |
| Quad-wiring or quad-amping | 12 | | |
| Standard models in fully Aktiv mode | 13 | | |
| Aktiv Bass connection (BALANCED AUDIO IN) | 13 | | |
| | | Upper frequency connections | 13 |
| | | Connection of fully Aktiv models (Klimax 350A, 340A and 320A) | 13 |
| | | Fine adjustment | 14 |
| | | Adjustment switches | 14 |
| | | Room acoustics | 15 |
| | | Operation | 15 |
| | | Klimax 345 | 17 |
| | | Unpacking | 17 |
| | | Fabric grille | 17 |
| | | Positioning | 17 |
| | | Cleaning | 17 |
| | | Connecting | 18 |
| | | Operation | 19 |
| | | Operating modes | 19 |
| | | Parameters | 19 |
| | | Technical Specification | 21 |
| | | Guarantee and Service | 23 |

Introduction

At Linn, we recognise that the way people access sound is changing. Entertainment systems are becoming ever more integrated and the line between music and movie systems is no longer clear. As the popularity of new and improved hi-resolution music formats increases, multi-channel systems are no longer for the movie enthusiast only.

As we change the way we access sound, the equipment we use to relay that sound must also change. A modern loudspeaker must offer greater levels of flexibility, reproduce a wider range of sounds and playback at a higher resolution to truly communicate the full potential of the system. The loudspeaker communicating the awesome force of an explosion in a movie blockbuster must be subtle enough to replay the tone and emotion of the softest female jazz vocal.

With this in mind, Linn presents Klimax - a gorgeous sounding high-performance loudspeaker system which combines simply stunning performance with luxurious appearance to deliver sumptuous, expressive and totally communicative playback.

The Klimax system

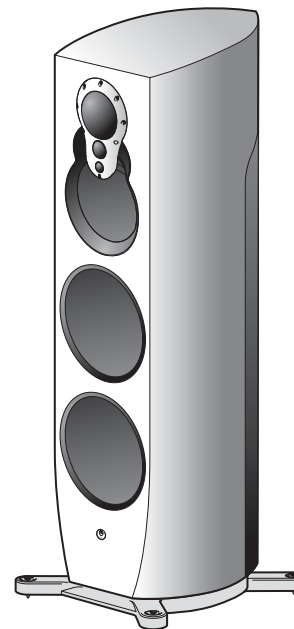

Klimax 350A - A fully Aktiv*, six-way, floor-standing loudspeaker that has been precision engineered to provide outstanding performance in medium to large sized listening areas. In music and AV applications, it provides exceptional audio playback, excelling in the faithful reproduction of all types of music, dialogue and effects. Klimax 350A features Linn Aktiv crossovers and includes 1500 watts of Linn Chakra** power amplification for optimum power and control. Its dual 8" (20cm) servo-controlled bass drive units, 6.5" (16.5cm) upper bass driver and 3-K Array** combine to offer exceptional performance throughout and beyond the audible range.

Klimax 350 - As Klimax 350A, but featuring advanced passive crossovers for upper-bass / 3-K Array, with the Aktiv lower-bass units driven by 1000 watts of integrated Chakra power amplification.

* See *Aktiv operation* section for further details.

** See *Features* section for further details.

Klimax 340A - A fully Aktiv* five-way centre-channel loudspeaker designed primarily to match the Klimax 350 floor-standing loudspeakers, ensuring co-ordinated front-of-system playback. It has also been tolerance-matched to the other Klimax loudspeakers to allow seamless system integration.

Klimax 340A features Linn Aktiv crossovers and includes 1300 watts of Linn Chakra** power amplification for optimum power and control.

A servo-controlled 8" (20 cm) lower-bass drive unit and an upper-bass 8" (20 cm) drive unit combine with the 3-K Array** to provide exceptional performance across the frequency range.

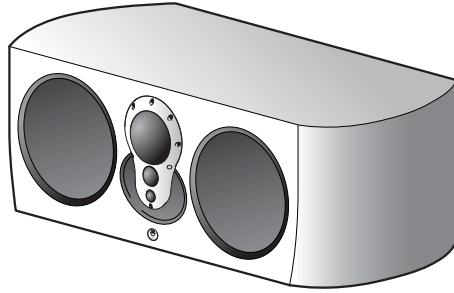

Klimax 320A - A fully Aktiv*, high-performance, four-way, compact loudspeaker. It features a 6.5" (16.5 cm) bass driver, which combines to great effect with the 3-K Array. Highly versatile, it is designed for use as the main loudspeaker in small to medium-sized listening areas or for surround-channel applications.

Integrated Aktiv crossovers and 700 watts of Chakra** power amplification, together with the advanced drive unit configuration, provide the ultimate sound from a compact loudspeaker.

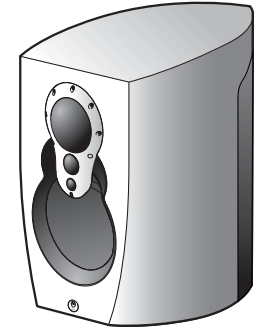

Klimax 345 - Bass reinforcement in the Klimax system is provided by the powered 345 subwoofer. The Klimax 345 is fully Aktiv*, is driven by an internal 500 W power amplifier and features a 12" (30 cm) servo-controlled driver in a 45-litre enclosure for pure, precise extended bass response.

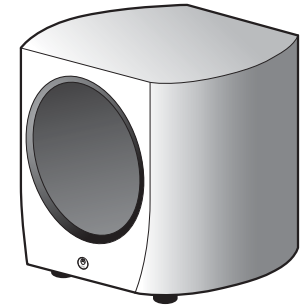

* See *Aktiv operation* section for further details.
 ** See *Features* section for further details.

Klimax features

Chakra amplifier technology (Klimax 350A, 350, 340A and 320A)

The Klimax loudspeakers incorporate Chakra, the very latest proprietary Linn power amplifier technology. Chakra perfectly combines the speed and precision of integrated MOSFET circuitry with smooth and highly robust discrete bipolar transistors for precisely controlled power at all listening levels.



Linn 3-K Array

(Klimax 350A, 350, 340A, and 320A)
This Linn designed and engineered acoustic array delivers optimised dispersion and performance. The array provides open, natural presentation and clear, precise dialogue and effects. All components used in the array are matched to a close tolerance, retaining sonic purity and consistency throughout.
The 3-K Array incorporates mid, tweeter and super-tweeter drive units.



Fully Aktiv* models

(Klimax 350A, 340A, 320A and 345)
On the fully Aktiv versions of the Klimax loudspeakers, all the circuitry required for full Aktiv operation - i.e. amplifier channels and Aktiv crossovers for the entire frequency range are integrated into the module at the rear of the loudspeaker cabinet. This allows direct connection to the audio output of a pre-amplifier or system controller, such as the Linn Kisto system controller.



Easy adjustment of key loudspeaker characteristics

(All models)
TREBLE SHELF (fully Aktiv models only), BASS SHELF and BASS ROLL-ON settings on the Klimax 350, 340 and 320 models can be adjusted using slide switches on the rear of the loudspeakers.
Seven different parameters can be adjusted on the Klimax 345 bass extension loudspeaker using its select and adjustment switches.

Advanced cabinet properties

(All models)

As well as presenting an elegant, contemporary and dynamic look, with its graceful, curved design; the arched shape maximises the overall strength and rigidity of the enclosure and optimises the internal acoustic properties of the cabinet.

The complex, pressure-formed natural laminate material, exquisitely finished with a real wood veneer provides the perfect combination of strength, flexibility, durability, sonic performance and a natural, beautiful finish.

Dual 8" (20cm) bass drivers

(Klimax 350A and 350)

The inclusion of two of these highly powerful, yet extremely precise lower-bass drive units provides a depth and quality of bass response that would otherwise necessitate a much larger enclosure. Each of these drive units has been specifically tuned to provide defined, musical control across the entire lower-bass frequency range.

Servo-controlled bass drivers

(Klimax 350A, 350 and 340A)

The movement of the principal bass driver(s) is constantly monitored by an accelerometer - a very accurate motion sensor, which is mounted on the voice coil of the driver. The resulting control data is then fed back to the servo circuitry, where it is compared with the drive unit's input signal, effectively fine-tuning the bass response in real-time to allow it to overcome any non-linearity of the driver and compensate for variations in environmental conditions. The end result is an output that is as true as possible to the original source material.

Servo-control, combined with Linn Aktiv crossovers provide the most precise levels of bass playback in any listening environment.

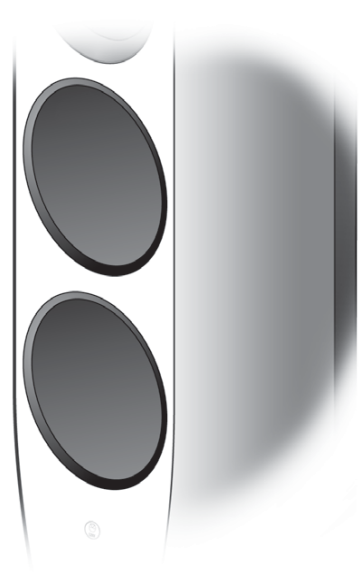

High quality 6.5" (16.5 cm) sandwich-cone bass drive unit

(Klimax 350A, 350, and 320A)

Layered cone design delivers precise, musical bass.

Sekret-fastener

(All models)

Invisible, flush fitting, loudspeaker grille technology.

Magnetic shielding

(All models)

To avoid magnetic interference with other household products such as a television or a mobile communications device, all of the loudspeakers within the Klimax system are magnetically shielded.

Aktiv operation

The term 'Aktiv' refers to the proprietary Linn active crossovers and loudspeaker configuration.

Aktiv or passive?

In passive mode, the output from the power amplifier is passed through the passive crossover in the loudspeaker, which results in some loss of audio signal as some of its energy is used to power the crossover circuitry and therefore is effectively lost.

In an Aktiv system, on the other hand, the crossover circuitry is mains powered and so does not rely on the signal. The fact that it is powered also allows advanced circuitry to be included, which exerts a much greater degree of control over the processing of the audio signal, providing a more precise audio output to the drive units. This results in significantly improved sonic performance.

Klimax 350, 340 and 320

Unpacking

We recommend that your Klimax loudspeakers are unpacked, installed and adjusted by an authorised Linn retailer.

IMPORTANT:

The Klimax loudspeakers are heavy; take great care when moving them. When unpacking, lifting or moving them, we recommend that two people are utilised in order to avoid personal injury.

If you are using a cutting implement to open the boxes, please be very careful not to puncture the packaging and damage the loudspeakers and accessories within.

Be very careful when handling the unpacked loudspeaker(s) - rings, bracelets, buttons on clothing etc can damage the veneer while lifting. Do not lay the speaker on its front and be careful not to touch the front of the loudspeaker while handling, in order to avoid damaging the drive units.

To unpack:

- Move the (boxed) loudspeaker to an uncluttered area adjacent to its eventual position (this will avoid any excessive moving and carrying of unpacked loudspeakers).
- Stand the loudspeaker box on its base. (In the case of the Klimax 350 stand the box upside down).
- Very carefully cut the bands holding the end-caps in place.
- Lift off the top end-cap.
- Remove the cardboard sleeve by lifting it straight up until it clears the top of the cabinet. (Or unclip wrap-around sleeve).
- Lift the loudspeaker out of the base end-cap and remove its protective bag.
- Once you have positioned the loudspeakers, VERY CAREFULLY snip the plastic tie holding the 3-K Array cover in place and remove the cover.

Notes:

If you require to stand the Klimax 350 or 320 upside down, use the end-cap to hold it in position.

We recommend that you retain the packaging in case you need to transport your loudspeaker(s) at a later date.

Each pair of Klimax 350 floor-standing loudspeakers is supplied with the following accessories:

- loudspeaker stand kit
- spike adjustment tool
- 2 mains cables

The Klimax 340 centre loudspeaker is supplied with the following accessories:

- spike kit
- mains cable

Each pair of Klimax 320 compact loudspeakers is supplied with the following accessories:

- spike kit
- 2 mains cables

Fabric grilles

The Klimax 350, 340 and 320 loudspeakers are supplied with fabric grilles. These grilles are held in place by Sekret-Fasteners (shielded magnets hidden within the cabinets). The fabric grilles can easily be removed by gently pulling them towards you.

IMPORTANT:

Do not attempt to remove the metal grilles.

Cleaning

Remove dust and fingerprints from the cabinets with a soft, dry, lint-free cloth. Avoid using domestic cleaning products as they may damage the veneer. The fabric grilles should be removed from the cabinets and cleaned carefully with a soft brush.

Positioning and levelling

We recommend that your Klimax loudspeakers are unpacked, installed and adjusted by an authorised Linn retailer.

To get the best from your Linn Klimax loudspeakers, it is important that they are positioned and levelled correctly. Please note, in order to achieve the very best from your Klimax loudspeakers, some adjustment may be required after positioning, levelling and connecting. See the *Fine adjustment* section.

Positioning

The very nature of the 3-K Array with its close driver proximity ensures uniform dispersion characteristics and therefore should not require any significant degree of toeing-in to improve performance.

A loudspeaker placed too close to a wall will tend to affect bass definition creating a bass 'bloom', so a minimum of 4" (10cm) is recommended between the back of a loudspeaker and the closest wall and a minimum distance of 12" (30cm) from the nearest side wall.

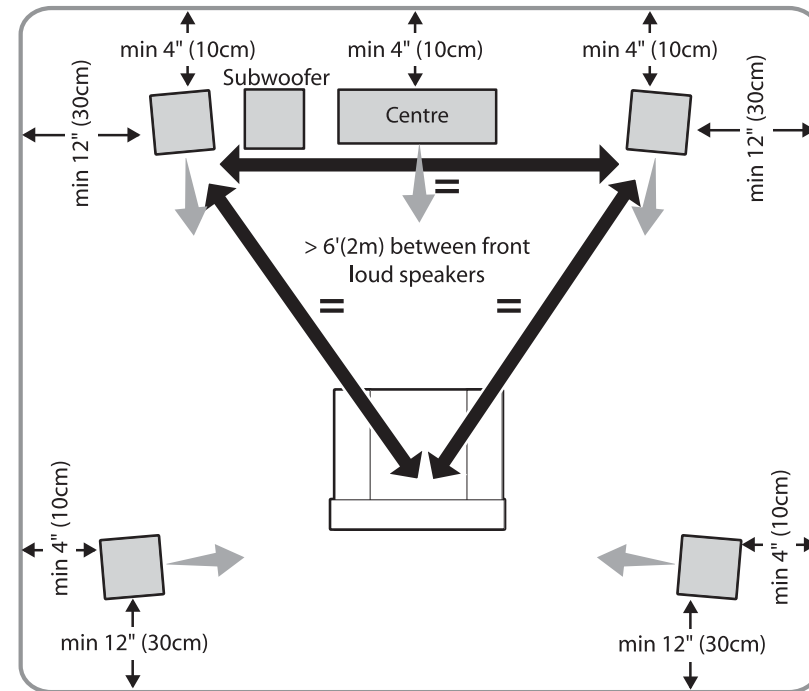
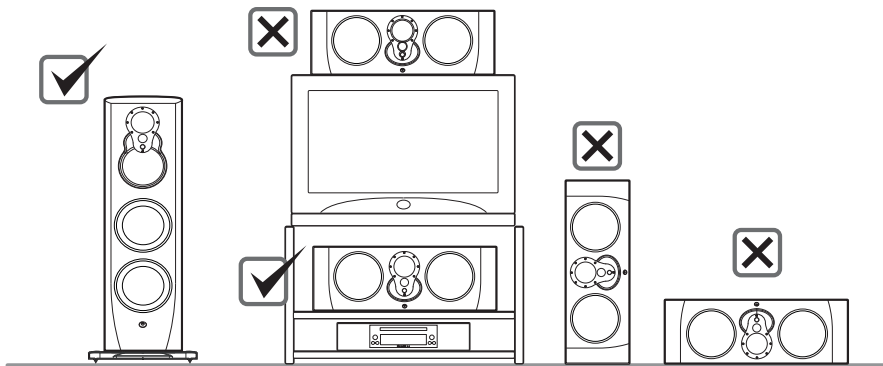
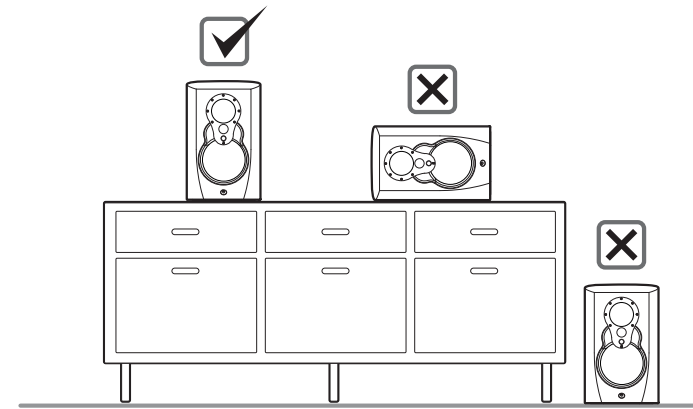

Levelling

All components in the Klimax loudspeaker system benefit from levelling which produces distinct improvements in soundstage and accuracy. A properly levelled loudspeaker will always perform more effectively than an unstable one; the actual loudspeaker cabinet can remain fixed whilst the drive units are allowed to move as precisely determined by the playback signal from the amplifier. Adjustable spikes or feet enable levelling on uneven floors, however these adjustments are subtle and will not compensate for excessively irregular floors.

The procedure for levelling each loudspeaker should be as follows:

- Very carefully (do not scratch the cabinet), use a spirit level to check if it is sitting level. If it is, gently rock the loudspeaker from front to back, side to side and diagonally to check for any movement. If none is present and the loudspeaker is sitting level, no adjustment to the spikes is necessary.

Note:

In the case of Klimax 350 models, a reading can be taken by placing the spirit level vertically against the front and sides.

- If the loudspeaker is not level, or moves when you rock it, loosen the appropriate lock nuts using the tool provided (1) and use a screwdriver to turn the spikes to adjust their height. (2).

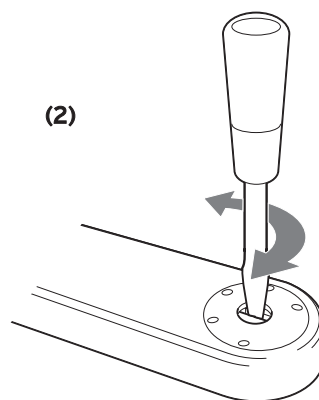
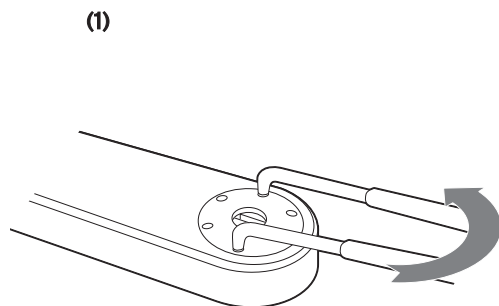

- Press down firmly on the top of the loudspeaker to ensure it is in close contact with your flooring.
- Use the spirit level as before and continue to adjust the spikes as required.
- When the loudspeaker is level and does not rock, use the screwdriver to hold the spike in place and tighten the lock nuts using the tool provided. (3)

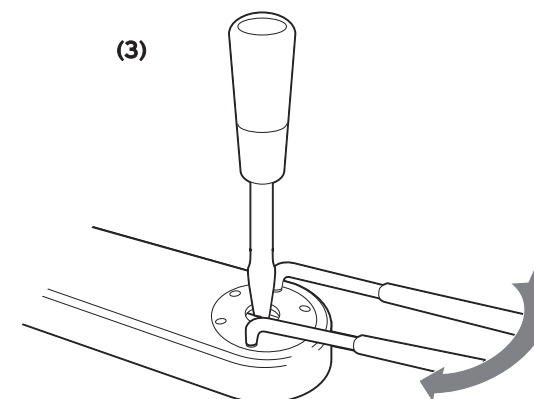

Note:

To protect wooden or tiled floors, the spikes can be placed on Linn Skeets which are available from your Linn retailer.

Connecting

We recommend that your Klimax loudspeakers are unpacked, installed and adjusted by an authorised Linn retailer.

General

IMPORTANT:

Before making any connections, switch off all products in your system and disconnect each Klimax loudspeaker from the mains.

Connection of standard Klimax 350 model

The back panels of the standard model of Klimax 350 loudspeakers are fitted with binding-post terminals for connection of the upper frequency signals (i.e. upper bass, mid, tweeter and super-tweeter). These terminals can be used as sockets for the connection of 4mm banana plugs or can be used as binding posts for the connection of bare wires or spade-terminated cables.

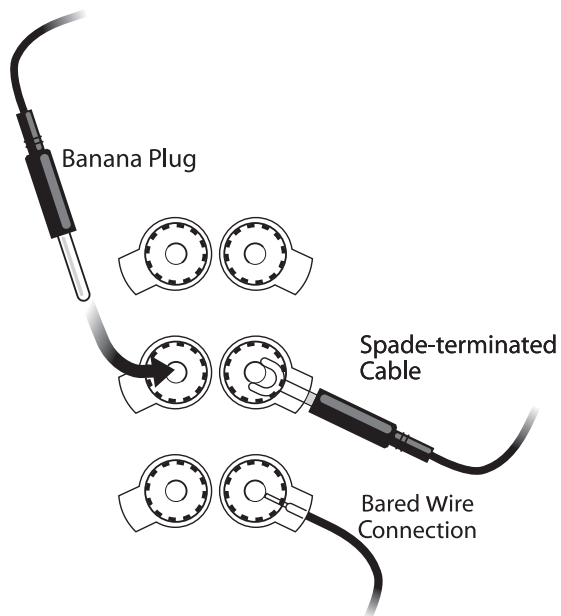

IMPORTANT: (BALANCED AUDIO IN)



Do not connect anything to the BALANCED AUDIO IN (Aktiv bass) socket - please consult your Authorised Linn Retailer. In the standard configuration (i.e. the factory setting), the signal going into the binding post terminals provides the audio to the Aktiv bass via an internal link. A modification can be carried out by your Authorised Linn Retailer to allow a direct connection to be made from your pre-amplifier to BALANCED AUDIO IN which would provide improved audio performance.

Wiring and amping options

The standard Klimax 350 is supplied with terminal link strips (factory-fitted). The links connect the terminals together for single-wiring, or can be cut or removed to provide multi-wiring or multi-amping options.

When connecting the standard models in passive mode, it will benefit the sonic performance to upgrade from single-wiring. Using a separate cable for each drive unit connection (multi-wiring) will tend to provide the best sound from a single amplifier channel; or to provide further improvement, use a separate amplifier channel for each drive unit connection (multi-amping).

For best audio performance however, your loudspeakers should be driven in AKTIV mode, which provides benefits over and above that which can be gained from multi-wiring/ multi-amping (see *Aktiv operation* section, above).

Please ensure that the positive (+) or red-coloured connectors from your amplifier(s) connect to the positive (+) connectors on your loudspeaker(s). And that the negative (-) or black-coloured connectors from your amplifier(s), connect to the negative (-) connectors on your loudspeaker(s).

Where external amplification is being used, Linn power amplifiers are recommended. If non-Linn amplifiers are being used in a multi-amping situation, please ensure that the gain figures match each other, in order to avoid any imbalance.

Link strip information

To remove / fit the link strips:

- Loosen the outer section of each binding post on one row of terminals (do not remove these posts completely).
- Slide the link strip diagonally outwards to remove.
- When refitting the strips, please ensure that they are fully and correctly inserted.
- Ensure that all the binding posts are tight (whether the strips are being refitted or not).
- Repeat the process for the second row.

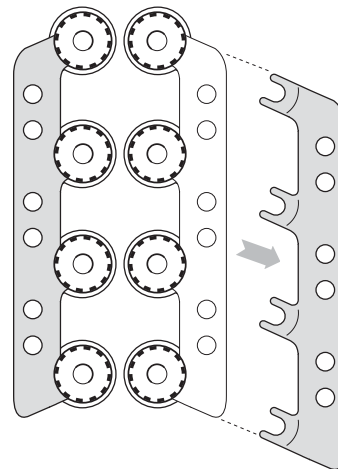

To modify the link strips for multi-wiring or multi-amping applications:

- Remove the link strip from the loudspeaker, as explained above.
- Determine where you require to make the cut (see multi-wiring/ multi-amping options below for guidance).
- Using a pair of strong snips or a small hacksaw, cut at an angle (example shown), using the holes as guides for cutting position and to help make snipping easier. If you will be using both sides of the separated link, ensure your cut creates a definite gap in order to eradicate the possibility of the links accidentally re-connecting, when fitted to the loudspeaker. Cutting across both holes as shown will ensure a good spacing.
- File down any sharp edges to prevent the possibility of injury.

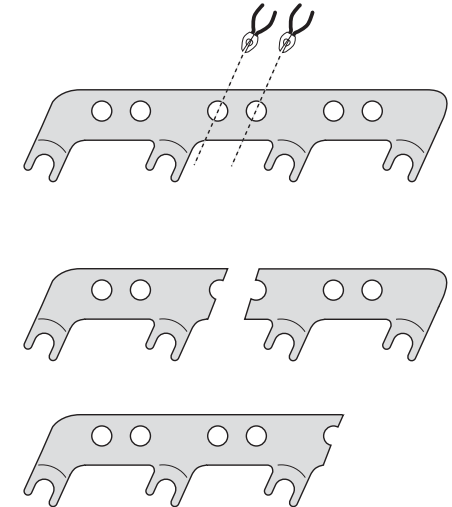

Important notes on using the link strips

The configurations below are only suggestions - others are possible. If you are trying other setups, we would advise that you consult an authorised Linn retailer and please bear in mind the following points:

Never use the strips to link positive (+) and negative (-) terminals together.

When multi-amping, ensure that the link strips do not short-circuit amplifier channels together. Shorting the outputs of separate amplifier channels together can damage the amplifier(s) and loudspeaker drive units.

Do not connect more than one strip per terminal.

Single-wiring

Position of link strips if single-wiring (i.e. using a single cable from one power amplifier channel). No link adjustments or cuts are required.

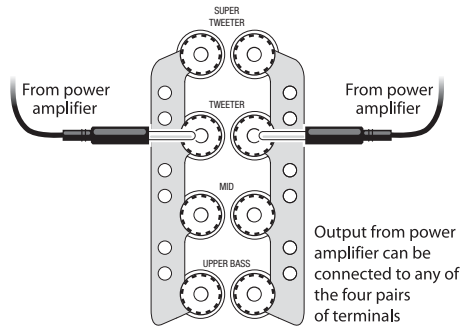

KLIMAX 350

Bi-wiring or bi-amping

Suggested position of separated link strips if bi-wiring (i.e. using two cables from one power amplifier channel) or bi-amping (i.e. using two power amplifier channels).

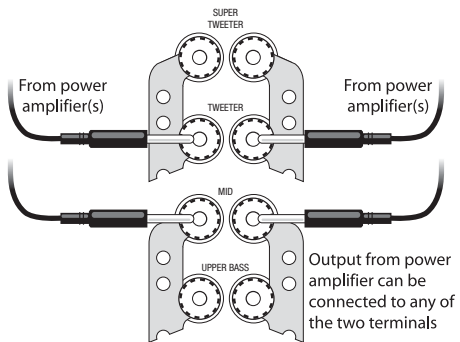

KLIMAX 350

Tri-wiring or tri-amping

Suggested position of separated link strips if tri-wiring (i.e. using three cables from one power amplifier channel) or tri-amping (i.e. using three power amplifier channels).

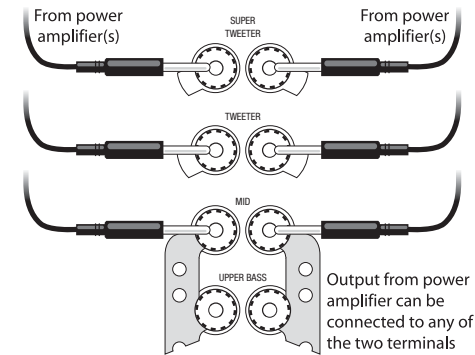

KLIMAX 350

Quad-wiring or quad-amping

Link strips **MUST** be removed if quad-wiring (i.e. using four cables from one power amplifier channel) or quad-amping (i.e. using four power amplifier channels).

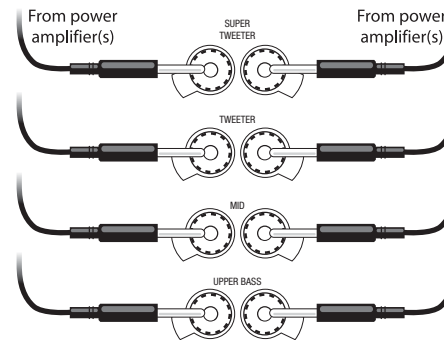

KLIMAX 350

Standard models in fully Aktiv* mode

For Aktiv operation of the standard Klimax 350 model using external power amplifiers and Aktiv modules, please connect as shown below.

IMPORTANT:

Standard models of Klimax 350 loudspeakers must have their crossover module and power amplifier configuration modified by your authorised Linn retailer before connecting.

Aktiv bass connection (BALANCED AUDIO IN)

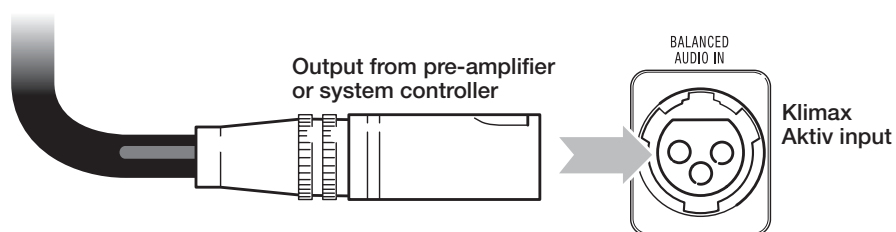

The Aktiv input is a balanced-audio connector and we recommend the use of a Linn Balanced Interconnect lead (e.g. Linn part no: CONN 889) or an interconnect lead with its connections configured to match with the Klimax bass input connections as shown.

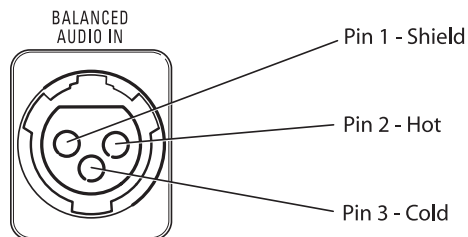

* See *Aktiv operation* section for further details.

Upper frequency connections

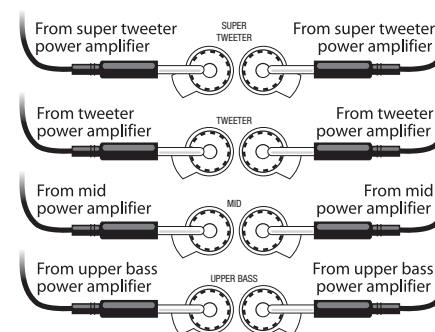

KLIMAX 350

IMPORTANT:

When using separate power amplifiers and Aktiv modules, please be very careful to connect all cables from the amplifier to the correct sockets on the loudspeaker. Wrong connection could result in damage to your loudspeaker drive units and/or amplifier.

Connection of fully Aktiv models (Klimax 350A, 340A and 320A)

Connect as described in the *Aktiv bass connection (BALANCED AUDIO IN)* section, above.

Fine adjustment

Once your Klimax loudspeakers are correctly positioned, levelled and connected, some tuning of the sound may benefit the performance.

The acoustics of a room are dependent on many factors including size, shape, contents and textures. The information below will assist in helping you to achieve optimum sound from your loudspeakers in any setting.

Adjustment switches

The Klimax loudspeakers are provided with adjustment switches on the back panel. The factory settings will provide the best performance in the majority of room settings, however if a room's acoustics are found to be a little bright or perhaps a bit bass-heavy, these switches allow certain parameters to be fine-tuned, in order to allow the loudspeaker performance to match the room acoustics more closely.

When making adjustments, the loudspeakers must first be correctly positioned and connected (see the *Positioning and levelling* section and the *Connecting* section). Then play a passage of music and listen, using the 'tune' method, i.e. how easy is it to follow the tune? Make a single adjustment and listen to the same passage of music again. Is it easier or more difficult to follow the tune?

Continue to do this (adjust/ listen/ adjust etc), one parameter at a time, until you focus the sound to its optimum, in terms of tuneful performance.

Adjustment switches - Klimax 350A, 340A and 320A fully Aktiv models

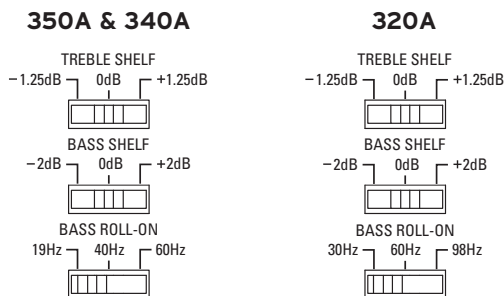

Adjustment switches - Klimax 350 standard model

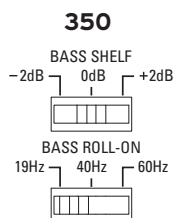

TREBLE SHELF

This switch adjusts the amplitude of the treble range.

The default setting (0 dB) provides a flat response (unity gain).

BASS SHELF

This switch adjusts the amplitude of the bass range.

The default setting (0 dB) provides a flat response (unity gain).

BASS ROLL-ON

Adjusting this parameter raises the lowest frequency produced by the loudspeaker. This can be used to provide better acoustic matching when a bass extension loudspeaker, such as the Klimax 345, is also being used.

Settings

| | |
|---------------------|--------------------|
| Klimax 350 and 340: | 19Hz*, 40Hz, 60Hz. |
| Klimax 320: | 30Hz*, 60Hz, 98Hz |

* Factory default setting

Room acoustics

When used in certain rooms it may also be beneficial to alter the room layout in order to achieve the very best performance.

If the sound seems overly bright, even after the Klimax's adjustment switches have been set, adding more in the way of soft materials will usually help - e.g. carpets, rugs, wall-hangings, heavy curtains, sofas etc. If the sound seems dull, reducing the amount of soft materials in the room can help. Also, breaking up flat, unbroken surfaces such as large areas of wall, ceiling, floor and large windows with furniture, fittings and other irregularly shaped items can prevent echoes and 'standing waves' (when sound waves bounce back and forth across a room instead of being dispersed).

Notes:

If you alter the acoustics of the room, it may then be necessary to re-adjust the loudspeaker settings to match the new characteristics of the layout. See *Adjustment switches*, above.

Klimax loudspeakers will function to specification from new and do not require any specific measures for 'running in'. After you have been using your loudspeakers for a period of time (perhaps a week or two, depending on conditions and usage patterns), the performance may improve slightly as the drive units and other major components adjust to their new surroundings.

If you have any difficulties in achieving the best from your Klimax loudspeakers, your Linn retailer will be able to examine your room setup and advise you on appropriate measures.

Operation

General

The blue LED will be dim when power is first applied and will remain dimmed when the amplifier is in standby mode.

Signal sensing

When an input signal is detected, the Chakra amplifier is enabled and the LED brightens. In the absence of an audio signal, the amplifier reverts to a low power standby mode after approximately 20 minutes.

The signal detector is quite sensitive and if there is noise in your system, such as hum or hiss, it could trigger the detector. If this occurs, try to eliminate the source of the noise.

Protection

Operation

If an amplifier channel overheats or detects an overload condition, the power supply for that channel will shut down in order to protect the amplifier and the loudspeaker drive unit(s) to which it is connected.

Please note: all channels that are powered by that same power supply will also shut down so more than one channel may be affected.

Duration

Once the condition that caused the amplifier to activate its protection has passed, the amplifier will automatically resume normal operation. How long the channels remain in protection will depend on the cause. If the protection operates for more than a few seconds, it could indicate overheating which may take some minutes of cooling to rectify.

A lengthier delay (10 minutes or more) could indicate a persistent overload condition (e.g. one of the components connected to the amplifier is faulty). Try switching the unit off at the mains for 30 minutes or so and try again. If it remains non operational, consult your retailer who can examine your system and determine the source of the problem.

Klimax 345

Unpacking

The Klimax 345 bass reinforcement loudspeaker is heavy: take care when removing it from its packaging.

The Klimax 345 loudspeaker is supplied with the following accessories:

- mains lead
- phono lead

To unpack:

- Move the (boxed) loudspeaker to an uncluttered area adjacent to its eventual position (this will avoid any excessive moving and carrying of unpacked loudspeakers).
- Stand the loudspeaker box on its base.
- Very carefully cut the bands holding the end-caps in place.
- Lift off the top end-cap.
- Remove the cardboard sleeve by lifting it straight up until it clears the top of the cabinet.
- Lift the loudspeaker out of the base end-cap and remove its protective bag.

We recommend that you retain the packaging in case you need to transport the Klimax 345 loudspeaker at a later date.

Fabric grille

The Klimax 345 loudspeaker is supplied with a fabric grille. This grille is held in place by Sekret-Fasteners (shielded magnets hidden within the cabinets). The fabric grille can easily be removed by gently pulling it towards you.

IMPORTANT:

Do not attempt to remove the metal grille.

Positioning

The Klimax 345 loudspeaker can be placed anywhere you find convenient but please consider the following points:

- The Klimax 345 loudspeaker is best suited to be positioned on a floor, not a table, shelf etc. It is heavy and must be stably supported.
- For best results, position your Klimax 345 loudspeaker as close as possible to either your left front or right front loudspeaker.
- Bass notes will be accentuated if the Klimax 345 loudspeaker is positioned close to a wall or in a corner.
- Experimenting with the position may be necessary in order to match the sound of the Klimax 345 loudspeaker with other loudspeakers in your system and the acoustics of the room.

Cleaning

Disconnect the Klimax 345 loudspeaker from the power supply before cleaning. Remove dust and fingerprints from the cabinet with a soft, dry, lint-free cloth. Avoid using domestic cleaning products on the cabinet as they may damage the veneer.

Connecting

IMPORTANT:

Do not turn on the mains supply until you have connected all other components.

Once all the other connections have been made, connect the Klimax 345 loudspeaker to a mains supply using the mains lead provided.

Connecting to an AV processor

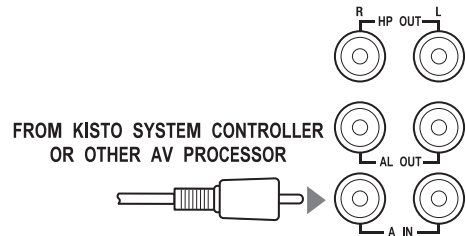

Connecting to a stereo pre-amplifier if used with large (full-range frequency response) loudspeakers (for example Klimax 350 or 320).

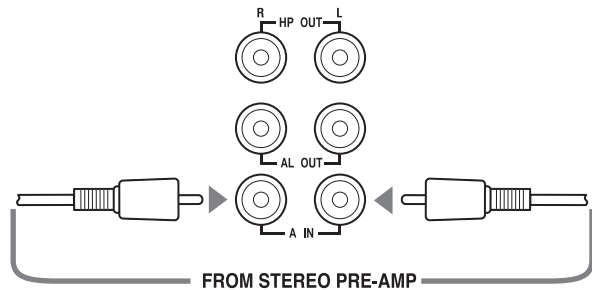

Connecting to a stereo pre-amplifier and power amplifier if used with small (limited bass response) loudspeakers.

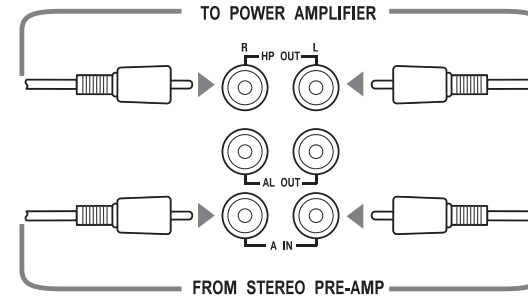

Note:

In the above configuration the Klimax 345 loudspeaker is being used to stop low bass notes from being sent to the main loudspeakers.

Connecting to another Klimax 345 loudspeaker

KLIMAX 345 - ONE

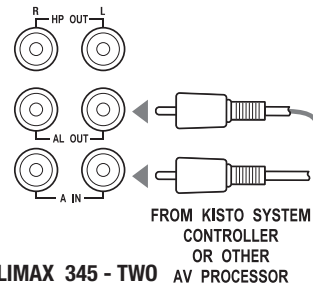

KLIMAX 345 - TWO

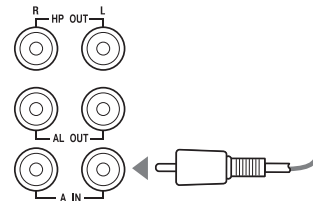

OR

KLIMAX 345 - ONE

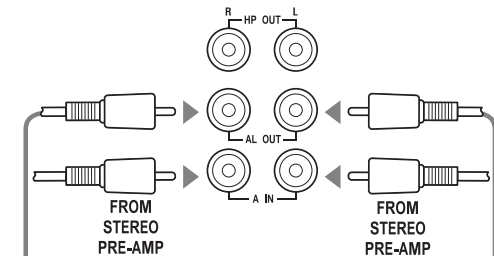

KLIMAX 345 - TWO

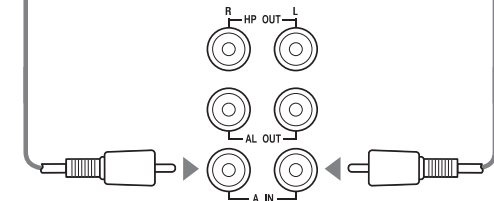



Operation

When you have made all the required connections, switch on the mains supply. Flashing bars will be shown on the back panel display for approximately 30 seconds. During this time the loudspeaker's servo circuitry is stabilising and no audio will be issued. When the display changes to show the standby symbol (see table below), the loudspeaker is ready to receive an audio signal.

Whenever the Klimax 345 loudspeaker is disconnected from the mains supply and then reconnected, wait until the standby symbol appears on the display before playing a disc.

Operating modes

| SYMBOL | MODE | MEANING |
|---|-----------------|---|
|  | Standby | The unit is waiting for an audio signal. In this mode the unit consumes minimal power. |
|  | On | The unit is fully powered-up. The unit will enter this mode as soon as it receives an audio signal. |
|  | Thermal Standby | The unit has overheated. During very demanding, sustained use the unit will go into Thermal Standby mode in order to allow itself to cool down. When in this mode the unit will not produce any sound. The unit will return to On mode when its temperature has dropped to its operating level. |

Parameters

The Klimax 345 loudspeaker is equipped with adjustable parameters (see next page) that enable you to alter its performance to suit your taste.

The parameters can only be adjusted when the Klimax 345 loudspeaker is not in standby mode.

Adjusting the parameters

To select the parameter you wish to adjust:

- Hold FEATURE.
- Repeatedly press UP or DOWN until the letter for the desired parameter appears.
- Release FEATURE.
- Repeatedly press UP or DOWN to change the setting.

A few seconds after the last key press the display changes to 

To restore the default settings:

- Disconnect the Klimax 345 loudspeaker from the mains supply and wait for the display to go blank.
- While holding FEATURE reconnect the mains supply.
- Continue to hold FEATURE until the display shows *H*

A few seconds after releasing FEATURE the display changes to 

Description and available settings for parameters

Default settings are shown in grey.

| Parameter | Symbol | 0 | 1 | 2 | 3 | 4 | 5 | 6 | 7 | 8 | 9 |
|--|--------|---|-----|-----|-----|--------------|-----|-----|-----|-----|-----|
| External high pass frequency.* Increasing the setting reduces the bass content sent to the external loudspeakers. (Hz) | H | | 10 | 50 | 75 | 100 | 115 | 135 | 160 | 190 | 235 |
| Internal high pass frequency. Increasing the setting raises the lowest frequency produced by the unit. (Hz) | U | | 18 | 22 | 25 | 30 | 34 | 40 | | | |
| Internal low pass frequency. Increasing the setting raises the highest frequency produced by the unit. Reducing the setting lowers the highest frequency produced by the unit. (Hz) | L | | 55 | 85 | 130 | No filtering | | | | | |
| Coarse gain. Every one step increase in the setting raises the gain (volume) of the loudspeaker by 5 decibels. Every one step decrease in the setting lowers the gain (volume) of the loudspeaker by 5 decibels. (dB) | G | | -15 | -10 | -5 | 0 | +5 | +10 | +15 | | |
| Fine gain. Every one step increase in the setting raises the gain (volume) of the loudspeaker by 1 decibel. (dB) | F | 0 | +1 | +2 | +3 | +4 | | | | | |

| Parameter | Symbol | 0 | 1 | 2 | 3 | 4 | 5 | 6 | 7 | 8 | 9 |
|--|--------|-----------|----|----|----|---|---|---|---|---|---|
| Bass equalisation. Every one step increase in the setting applies an additional 3dBs at 30 Hz and below. (dB@30 Hz) | b | 0 | +3 | +6 | | | | | | | |
| Time out. Length of time before unit will go into standby after audio input ceases. (mins) | T | Always on | 5 | 10 | 20 | | | | | | |

* Only for use when the Klimax 345 loudspeaker is connected to a power amplifier (see *Connecting* section in this chapter).

Technical Specification

| | KLIMAX 350 / A | KLIMAX 340A | KLIMAX 320A |
|--|--|--|---|
| Type | 6-way floorstander | 5-way centre | 4-way compact |
| Mains input voltage (auto-sensing) | 90 - 135V 180 - 265V | 90 - 135V 180 - 265V | 90 - 135V 180 - 265V |
| Mains fuse | Schurter FST0034.3217 10 A 250 V | Schurter FST0034.3217 10 A 250 V | Schurter FST0034.3217 10 A 250 V |
| Power consumption (fully AKTIV models) Standby Rated Maximum (continuous) | 49 W 100 W 600 W | 42 W 100 W 600 W | 27 W 50 W 300 W |
| Power consumption (standard model) Standby Rated Maximum (continuous) | 30 W 50 W 300 W | | |
| Drive units | 13 mm (0.5") / 25 mm (1") / 75 mm (3") domes, 165 mm (6.5") upper bass, 2 x 200 mm (8") servo lower bass | 13 mm (0.5") / 25 mm (1") / 75 mm (3") domes, 1 x 200 mm (8") upper bass, 1 x 200 mm (8") servo lower bass | 13 mm (0.5") / 25 mm (1") / 75 mm (3") domes, 165 mm (6.5") servo bass. |
| Efficiency | 87 dB for 1 watt at 1 m (1 kHz) | 87 dB for 1 watt at 1 m (1 kHz) | 87 dB for 1 watt at 1 m (1 kHz) |
| Crossover options | Fully Aktiv (internal modules) Fully Aktiv (internal lower bass / external upper bass and 3-K Array) Aktiv lower bass / passive upper bass and 3-K Array | Fully Aktiv (internal modules) | Fully Aktiv (internal modules) |
| TREBLE SHELF settings (fully Aktiv models only) | -1.25 dB*, 0 dB, +1.25 dB | -1.25 dB*, 0 dB, +1.25 dB | -1.25 dB*, 0 dB, +1.25 dB |
| BASS SHELF settings | -2 dB*, 0 dB, +2 dB | -2 dB*, 0 dB, +2 dB | -2 dB*, 0 dB, +2 dB |

* default setting

| | KLIMAX 350 / A | KLIMAX 340A | KLIMAX 320A |
|------------------------------------|--|--|--|
| BASS ROLL-ON settings | 19 Hz*, 40 Hz, 60 Hz | 19 Hz*, 40 Hz, 60 Hz | 30 Hz*, 60 Hz, 98 Hz |
| Frequency response - passive | 20 Hz - 33 kHz | 30 Hz - 33 kHz | 55 Hz - 33 kHz |
| Frequency response - active | 20 Hz - 33 kHz | 30 Hz - 33 kHz | 55 Hz - 33 kHz |
| Crossover points | All Butterworth at 105 Hz, 392 Hz, 3.8 kHz, 10.9 kHz | All Butterworth at 105 Hz, 392 Hz, 3.8 kHz, 10.9 kHz | All Butterworth at 392 Hz, 3.8 kHz, 10.9 kHz |
| Nominal impedance - passive | 4 Ω | 4 Ω | 4 Ω |
| Impedance - active (upper-bass) | 8 Ω | 8 Ω | 8 Ω |
| Impedance - active (mid) | 8 Ω | 8 Ω | 8 Ω |
| Impedance - active (tweeter) | 6 Ω | 6 Ω | 6 Ω |
| Impedance - active (super-tweeter) | 4 Ω | 4 Ω | 4 Ω |
| Connection options | Up to 4-way by wire or amplifier | | |
| Magnetic shielding | Yes | Yes | Yes |
| Operating volume | 50 litres | 40 litres | 20 litres |
| Dimensions | 1100 mm (H) x 312 mm (W) x 430 mm (D) | 290 mm (H) x 840 mm (W) x 400 mm (D) | 473 mm (H) x 292 mm (W) x 410 mm (D) |
| Shipping dimensions | 1188 mm (H) x 432 mm (W) x 612 mm (D) | 441 mm (H) x 1004 mm (W) x 625 mm (D) | 658 mm (H) x 394 mm (W) x 584 mm (D) |
| Weight | 54 kg / 119 lb | 46.5 kg / 102.5 lb | 19.5 kg / 43 lb |
| Shipping weight | 64.8 kg / 143 lb | 51.5 kg / 114 lb | 23.6 kg / 52 lb |

| KLIMAX 345 | |
|------------------------------------|--|
| Type | 1-way bass reinforcement |
| Drive unit | 300 mm (12") servo bass |
| Mains input voltage (auto-sensing) | 90 - 135V 180 - 265V |
| Mains supply frequency | 50 - 60 Hz |
| Mains fuse | 6.3 A, slow-blow, 5 x 20 mm, Littlefuse 21806.3 |
| Magnetic shielding | Yes |
| External frequency response | Adjustable from 10 Hz - 235 Hz in 9 steps. Default is 10 Hz. |
| Internal frequency response | Adjustable from 55 Hz - 130 Hz in 3 steps and flat (to allow external low pass filtering). Default is 55 Hz. |
| Gain | Adjustable in 1 dB steps |
| Line input impedance | 18 k Ω |
| Line output level | Electronically in parallel with line input |
| Power consumption | |
| Standby | 11 W |
| Rated | 60 W |
| Maximum (continuous) | 150 W |
| Output power | 500 W RMS, 1000 W peak |
| Operating volume | 45 litres |
| Dimensions | 420 mm (H) x 491 mm (W) x 410 mm (D) |
| Shipping dimensions | 596 mm (H) x 595 mm (W) x 534 mm (D) |
| Weight | 27 kg / 59.5 lb |
| Shipping weight | 30 kg / 66 lb |

Guarantee and Service

This product is guaranteed under the conditions which apply in the country of purchase and your statutory rights are not limited. In addition to any statutory rights you may have, Linn undertake to replace any parts which have failed due to faulty manufacture. To help us, please ask your Linn retailer about the Linn warranty scheme in operation in your country.

In parts of Europe, the United States of America and some other markets, extended warranty may be available to customers who register their purchase with Linn. You can register your warranty online at www.linn.co.uk

Warning

Unauthorised servicing or dismantling of the product invalidates the manufacturer's warranty. There are no user serviceable parts inside the product and all enquiries relating to product servicing should be referred to authorised retailers only.

Technical support and information

For technical support, product queries and information, please contact either your local retailer or one of the Linn offices opposite.

Full details of your local retailer/distributor can be found on the Linn web site: www.linn.co.uk

Important

- Please keep a copy of the sales receipt to establish the purchase date of the product.
- Please ensure that your equipment is insured by you during any transit or shipment for repair.

Linn Products Limited

Glasgow Road
Waterfoot
Eaglesham
Glasgow G76 0EQ
Scotland, UK

Phone: +44 (0)141 307 7777
Fax: +44 (0)141 644 4262
Helpline: 0500 888909
Email: helpline@linn.co.uk
Website: www.linn.co.uk

Linn Incorporated

8787 Perimeter Park Boulevard
Jacksonville
FL 32216
USA

Phone: +1 (904) 645 5242
Fax: +1 (904) 645 7275
Helpline: 888-671-LINN
Email: helpline@linninc.com
Website: www.linninc.com

Linn Deutschland GmbH

Hühnerposten 1d
D-20097 Hamburg
Deutschland

Phone: +49-(0) 40-890 660-0
Fax: +49-(0) 40-890 660-29
Email: info@linngmbh.de
Website: www.linn.co.uk